

JUXTA W Series General Specification

Model WX3□-VC (Variable software type)
WX4□-VC (Fixed software type)
Velocity Unit

JUXTA

1. GENERAL

This is a variable or fixed software type computing unit which accepts a mV signal from various converters and outputs an isolated DC voltage or current signal after velocity computation using the velocity computing time set by a handy terminal or variable resistor.

2. SPECIFICATIONS

Model	WX3A-VC, WX3V-VC	WX4A-VC, WX4V-VC
Input signal	DC voltage signal: 1 point	DC voltage signal: 1 point Volume setting
Measuring range	-2 to 10 mV (There is accuracy limitation for spans of more than 3 mV and less than 10 mV.) -10 to 50 mV (For span of more than 10 mV) -50 to 250 mV (For span of more than 50 mV) -100 to 1250 mV (For span of more than 250 mV) (*1)	
Input resistance	1 MΩ (At power failure: More than 3 KΩ)	
Output signal	4 to 20 mA, 2 to 10 mA, 1 to 5 mA, 0 to 20 mA, 0 to 16 mA, 0 to 10 mA or 0 to 1 mA DC 0 to 10 mV, 0 to 100 mV, 0 to 1 V, 0 to 10 V, 0 to 5 V, 1 to 5 V or -10 to +10 V DC	
Computing equation	$Y = \frac{X - X_L}{2} + 50\%$ X: The present input X _L : The previous input	
Velocity computing time range	0 to 7990 sec. (0.0 to 799.0%) (*2)	0 to 1000 sec. (0 to 1.000 V)
Time constant setting range	0.0 to 799.0 sec. (0.0 to 799.0%) (*3)	
Basic accuracy	±0.2% of measuring span	
Signal insulation	Between any of input signal, output signal, power supply circuits and grounding	
Insulation resistance	Between any of input, output and power (DC driven) Between any of input, output, power and grounding (AC driven) 100 MΩ/500 V DC	
Dielectric strength	Between input and output/power: 1500 V AC/min. and between output and power: 500 V AC/min. (DC driven) Between any of input, output, power and grounding: 1500 V AC/min. (AC driven)	
Power supply voltage	85 to 264 V AC 47 to 63 Hz, or 24 V DC ±10%	
Ambient temperature/humidity	0 to 50°C (32 to 122°F) and 5 to 93% relative humidity (No condensation)	
Effect of ambient temperature	±0.2% of span for 10°C (50°F) change	
Effect of power supply voltage	±0.2% of span for 85 to 264 V AC or 24 V DC ±10% variation	
Power consumption	100 V AC, 7.0 VA (voltage output) and 100 V AC, 8.5 VA (current output) 24 V DC, 60 mA (voltage output) and 24 V DC, 82 mA (current output)	
Dimensions	72 (2.83") H × 48 (1.89") W × 127 (5.00") D mm (inch)	
Weight	Approx. 150 g (DC driven), 280 g (AC driven)	
Accessories	Tag number label : 1 sheet Mounting blocks: 2 pcs.	

Specify the following:

(*1) Measuring range from □ to □mV.

Range accuracy for span of less than 10 mV: $0.2 \times 10 / (\text{mV input span}) \%$

(*2) Velocity computing time: □sec

(*3) 1st-order lag time constant: □sec

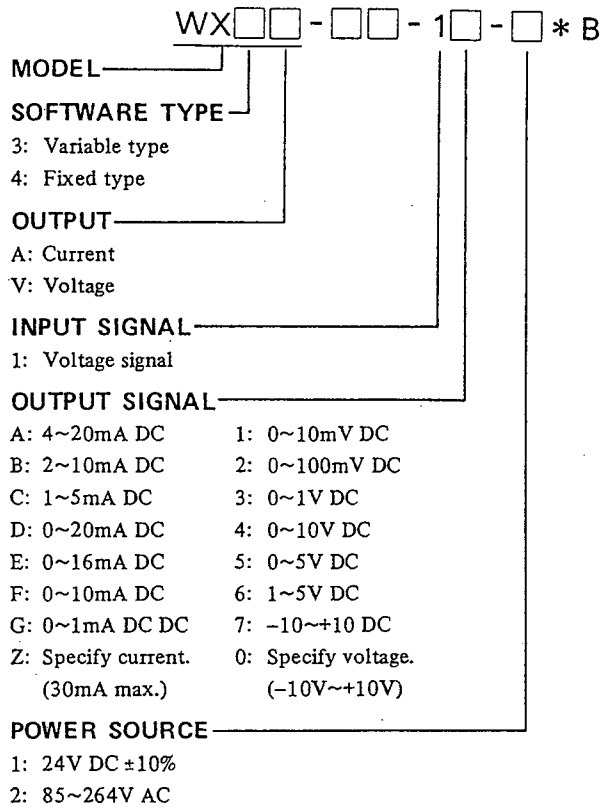

Ordering Information

Input Measuring Range		
Range name	Allowable min. span	Allowable Measuring Range
HH	250 mV	-100 ~ 1250 mV
H	50 mV	-50 ~ 250 mV
L	10 mV	-10 ~ 50 mV
LL	3 mV	-2 ~ 10 mV
However, accuracy of less than 10 mV span is $0.2\% \times \frac{10 \text{ mV}}{\text{Input span (mV)}} (\%)$		
Recommended Input Range		
Voltage signal		0 ~ 10 mV DC 0 ~ 100 mV DC 0 ~ 1V DC

OUTPUT RESISTANCE AND LOAD RESISTANCE

Output Signal	Load Resistance	Output Impedance
4 to 20mA DC	0 to 750Ω	5MΩ or more
2 to 10mA DC	0 to 1500Ω	
1 to 5mA DC	0 to 3000Ω	
0 to 20mA DC	0 to 750Ω	
0 to 16mA DC	0 to 900Ω	
0 to 10mA DC	0 to 1500Ω	
0 to 1mA DC	0 to 15kΩ	

Output Signal	Load Resistance	Output Impedance
0 to 10mV DC	100kΩ or more	100Ω or less
0 to 100mV DC		
0 to 1V DC	2kΩ or more	1Ω or less
0 to 5V DC		
1 to 5V DC	10kΩ or more	
0 to 10V DC		
-10 to +10V DC		

Subject to change without notice for grade up quality and performance